

CKP-Series

J1939 Customizable Keypads

PRODUCT WEBPAGE

request sample, configure part, watch video



Compliant with SAE J1939 CAN standards, the CKP-Series is a customizable membrane keypad featuring laser etched legends and up to three dimmable LED function lights per button, which also offer diagnostic feedback by blinking if there is a fault. With above and below panel sealing protection, the CKP-Series can be installed inside or outside the cab.

12/24 VDC **1,000,000** Operations **IP6K9K Sealing**
 for above panel components

Typical Applications

- Commercial Vehicles
- Construction
- Mining
- Agricultural
- Military

Design Features

LOW PROFILE DESIGN

0.57 inch [14.48 mm] thickness (see dimensional specs for more detail)



Front View

SEALING PROTECTION

Fully sealed IP6K9K above panel

LED FUNCTION LIGHTS

One, two, or three LED Function Lights per button. Colors include Amber, Green, Red or Blue

CUSTOMIZABLE ICONS

Choose from our standard library of icons or use custom icons

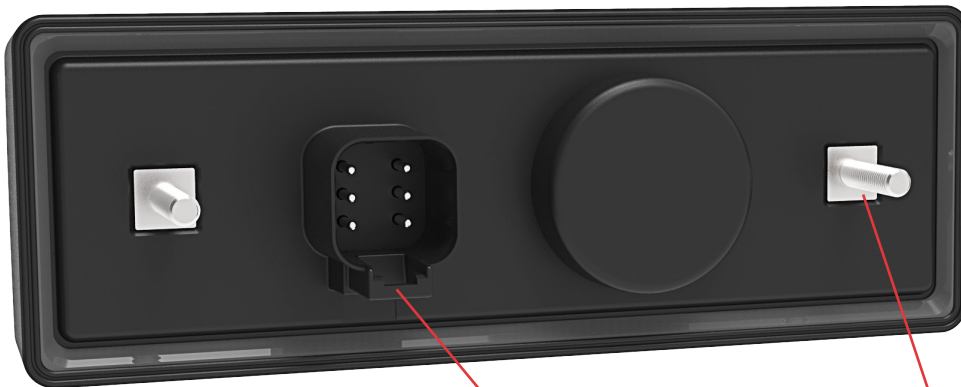

Back View

SEALING PROTECTION

Fully sealed IP6K8 below panel when connected

CONNECTOR

Mates to the Deutsch DT-Series Connector

MOUNTING STUDS OR WINGS

10-32 Mounting Studs (2x4, 2x5, 2x6)
Mounting Wings (2x2, 2x3)

Related Products



CLTM12-S-Series >
Load Controller



CKJ-Series >
Jog Switch



VM-Series >
Operator Control Module

Tech Specs

General

Illumination	LED backlit icons and function lights. Up to 3 function lights per button. Dimmable illumination, controlled by CAN messages
Connection / Wiring	Deutsch DT-Series connector (See Dimensional Specs)

Electrical

Operating Voltage	Designed for 12/24 Volt systems Minimum 8 VDC Maximum 32VDC
Sleep Mode	Low current sleep mode draws less than 1.5 mA throughout the supply voltage range, and wakes on keypress or CAN message
Supply Voltage Ratings	The keypad passes SAE J1455 section 4.13.1 for power up, operating voltage, over voltage, reverse polarity, and short circuit
EMC	Transient immunity: ISO 11452-2, 100 V/m, 20 MHz to 2,000 MHz, Class A per ISO 11451-1 Conducted Transient immunity: ISO 7637-2:2004, Annex A Table A2 (for 24V systems), Class A ESD immunity: ISO 10605:2001, Test level IV (8 kV direct discharge, 15 kV air discharge) Transient Emission: ISO 13766, Broadband: Annex D, Narrow band: Annex E, 30-1000 MHz

Mechanical

Overall Dimensions	See Dimensional Specs
Panel Cutout	See Dimensional Specs
Endurance	Each button functions for at least 1,000,000 total actuations (100,000 actuations at -40°C, 100,000 actuations at +85°C, and 800,000 actuations at +25°C)

Software

CAN Protocol	CAN 2.0b type interface as defined by SAE J1939
--------------	---

Environmental

Thermal	-40°C to +85°C IEC60068-2-1 Cold Soak IEC60068-2-2 Heat Soak IEC60068-2-14 Cycling/Shock
Solar Radiation	IEC 60068-2-5, procedure B, 10 cycles, Total irradiation per cycle = 22.4 kWh/m ²
Low Pressure	IEC 60068-2-13
Humidity	Soak: IEC 60068-2-78, 93% RH (±3%), 10 day cycle IEC 60068-2-30, test Db: Damp Heat cycle (12 hr. cycles for each variant) 6 cycles total
Ingress Protection	ISO 20653, IP6K9K, for above panel components of actual switch only. IP6K8, for below panel components of actual switch only. (when connected)
Shock and Bump	IEC 60068-2-27, Shock 500 m/s ² 11 milliseconds, Bump 400 m/s ² 6 milliseconds 600 cycles
Drop Test	IEC 60068-2-31, Free fall, Procedure 1, 1000 mm height, drop on all 3 axes in both directions
Vibration	IEC 60068-2-6, Swept sine wave section 8.2, 5 - 500 Hz 20 cycles 5g acceleration. IEC 60068-2-6, Vibration sinusoidal, section 8.1, 10 - 2000 Hz, 5g acceleration. IEC 60068-2-64, Method 1, random excitation, 10 - 350 Hz, 5 hours in each axis
Chemical Resistance	IEC 60068-2-74, Class B, Engine Oil, Diesel, Hydraulic Oil, Ethylene Glycol, Urea Nitrogen, Liquid Lime, NPK Fertilizer, Ammonia, Calcium Chloride, Brake fluid
Corrosion Resistance	IEC 60068-2-52, Test Kb, Severity level 4
Weathering/Cracking Resistance	ASTM D1171-99, method A, 72 hours
Abrasion/Wear Resistance	ASTM F2357; 40 cycles with .25" paper at 175g force

Physical

Operating Force	10 ± 3 N [2.25 ± .67 lbs]
Mounting	Clips or studs (See Dimensional Specs), Vertically or horizontally
RoHS	Compliant
REACH	Compliant
Connector	Deutsch DT-Series 6 pin

Tech Specs continued on next page

Tech Specs

Software Interface Integration

Click below on integrating the CKP-Series into J1939 CAN network:

www.carlingtech.com/sites/default/files/documents/ckp-series_interface.pdf

Tables

Table A: Standard Illumination

Type	Red	Green	Amber	Blue	White
Backlight	---	---	---	---	Yes
Function	Yes	Yes	Yes	Yes	---

Table B: Operation Current Values

	2x2	2x3	2x4	2x5	2x6
12V, 10% Luminance	---	---	---	---	---
Sleep (mA) Max	.9	.9	.9	.9	.9
Operate (mA) Max	16	19	29	30	40
24V, 10% Luminance	---	---	---	---	---
Sleep (mA) Max	.7	.7	.7	.7	1
Operate (mA) Max	9	10	15	16	35

Ordering Scheme

Part 1: Keypad

Sample Part No. **CKP 1 - 1 A 1 - A B - A - J 000 /**

Selection 1 2 3 4 5 6 7 8 9 10

1. SERIES

CKP CKP-Series Keypad

2. KEYPAD STYLING

1 Standard

3. BUTTON LAYOUT

1 Two by Six
2 Two by Five
3 Two by Four
4 Two by Three
5 Two by Two

4. KEYPAD ORIENTATION

A Landscape
B Portrait
C Reverse Landscape
D Reverse Portrait
 See Orientation Diagrams page

5. KEYPAD COLOR

1 Black

6. BACKLIGHT

A White

7. FUNCTION LIGHT COLOR

B Amber
C Green
D Red
E Blue

8. NON-ILLUMINATED IMAGE COLOR

A White

9. NETWORK TYPE

J J1939 (250K BAUD Rate) **K** J1939 (500K BAUD Rate)

10. SOURCE ADDRESS

The Source Address is a unique number (**000-248**) assigned to each node on a CAN network, and is determined based on the specific CAN architecture of each customer application.

[Configure Complete Part Number >](#)

Part 2: Icon Artwork (Select 12 buttons for 2x6, 10 buttons for 2x5, 8 buttons for 2x4, 6 buttons for 2x3, and 4 buttons for 2x2.)

Button 1 2 RS Function Icon Code	Button 2 2 RA Function Icon Code	Button 3 3 UV Function Icon Code	Button 4 3 UW Function Icon Code	Button 5 6 MT Function Icon Code	Button 6 8 UB Function Icon Code
Button 7 8 NN Function Icon Code	Button 8 8 PU Function Icon Code	Button 9 5 PR Function Icon Code	Button 10 5 PP Function Icon Code	Button 11 4 RH Function Icon Code	Button 12 4 NU Function Icon Code

FUNCTION LIGHT CODE

		Landscape	Portrait	Reverse Landscape	Reverse Portrait		Landscape	Portrait	Reverse Landscape	Reverse Portrait	
1	No Function Light					5	Closed-Open-Open				
2	Open-Closed-Closed					6	Open-Closed-Open				
3	Closed-Open-Closed					7	Open-Open-Closed				
4	Closed-Closed-Open					8	Open-Open-Open				

ICON CODE

00 For standard icons, see Standard Legends Code page. For additional icons, please consult factory.

Dimensional Specs

inches [millimeters]

2x2 and 2x3 Configurations

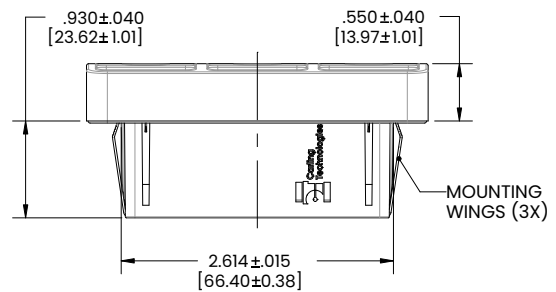
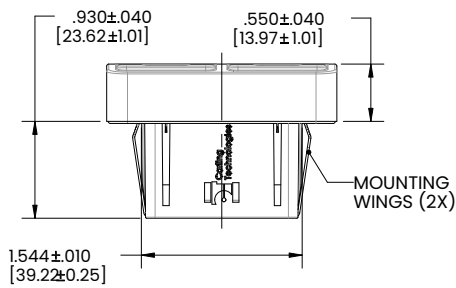
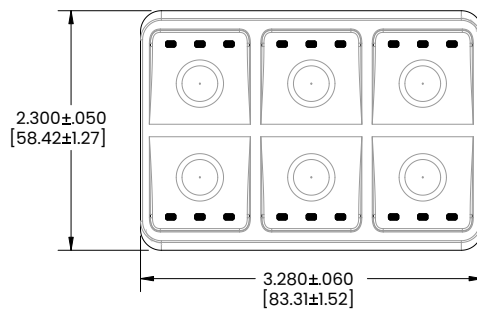
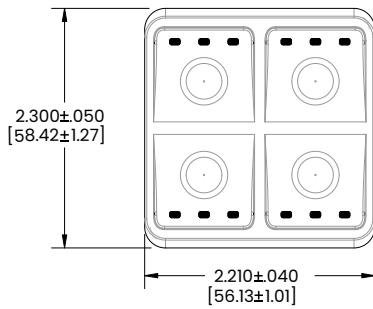

MATES TO THE DEUTSCH DT-SERIES CONNECTOR

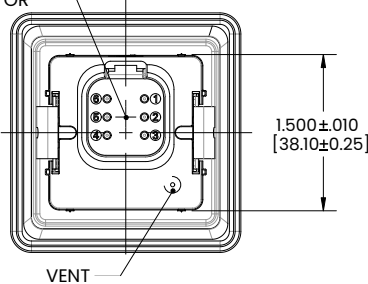

MATES TO THE DEUTSCH DT-SERIES CONNECTOR

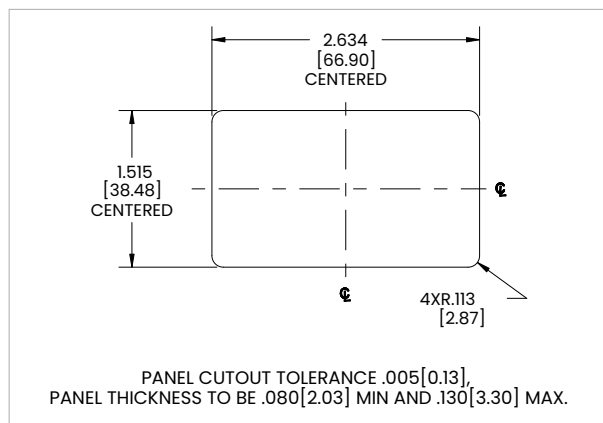
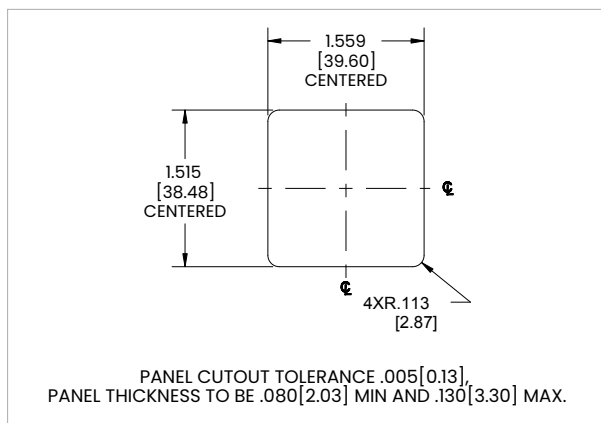
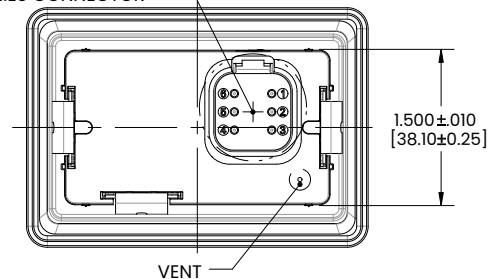

Notes:

- Do not puncture or plug the vent

Dimensional Specs

inches [millimeters]

2x4 and 2x5 Configurations

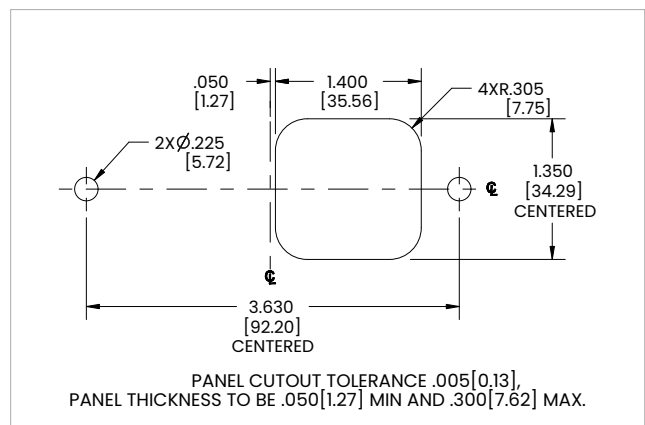
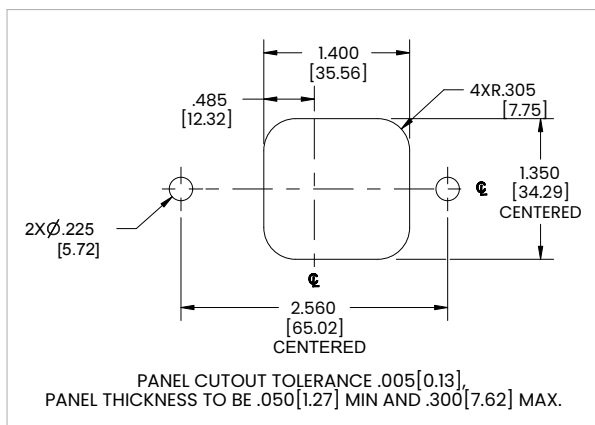
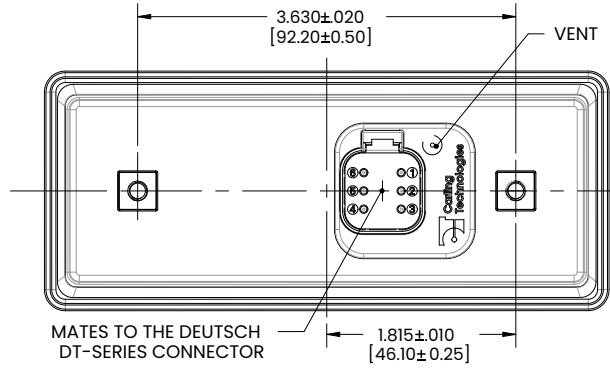
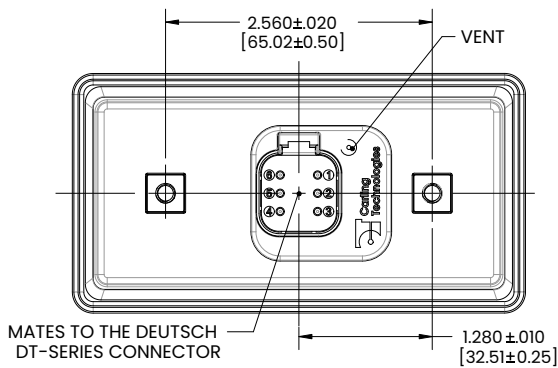
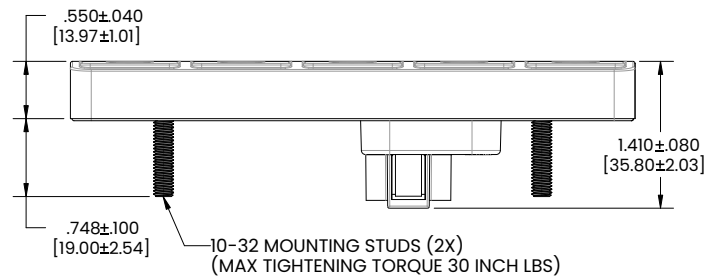
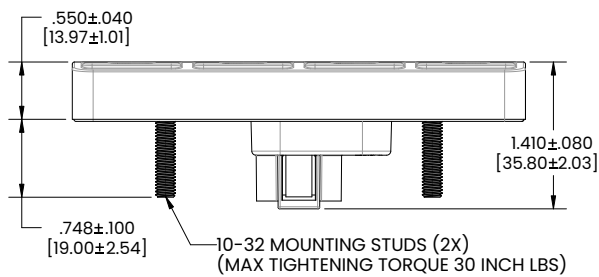
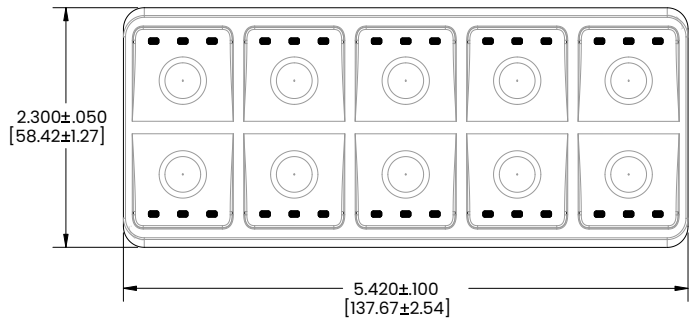
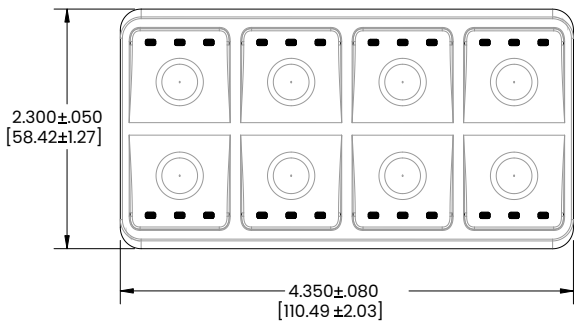

Notes:

- Do not puncture or plug the vent

Dimensional Specs

inches [millimeters]

2x6 Configuration

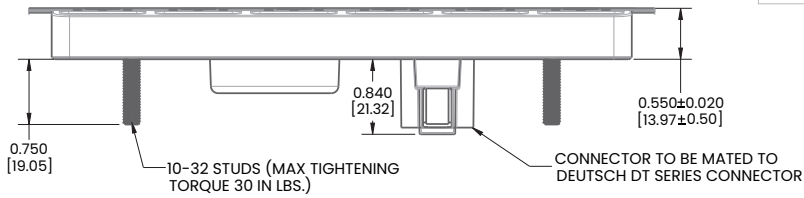
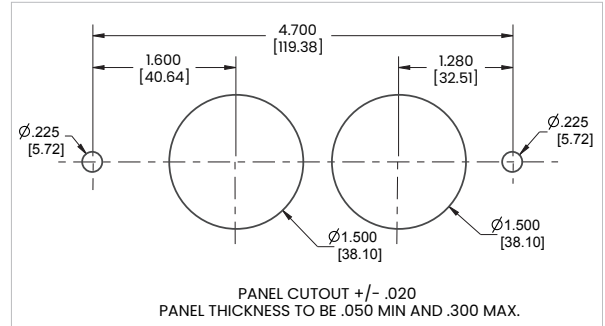
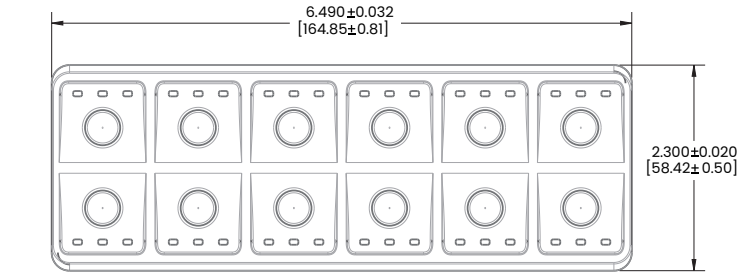

PIN OUT AS SHOWN BELOW FOR ALL CONFIGURATIONS (2x2, 2x3, 2x4, 2x5, and 2x6)

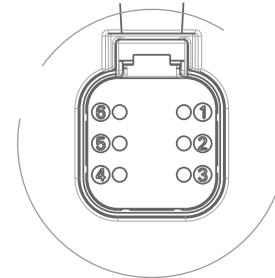
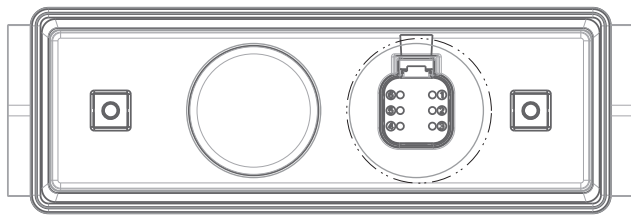

NO.	DESIGNATION
1	BATT +
2	CAN L
3	BATT -
4	IGN_ON
5	CAN H
6	CAN SHIELD

Orientation Diagrams

Icon Artwork Button Number Layout

A: Landscape



B: Portrait



D: Reverse Portrait



C: Reverse Landscape



Standard Legend Codes

YK	UA	UB	US	UV	UW	UX	UY	MP	MR	PX	MS	MT
VU	MW	NZ	NX	NY	YM	VW	PS	PW	PZ	WG	WM	RN
			NAV LIGHTS	COURT LIGHTS	PANEL LIGHTS	ANCH LIGHTS	HEAD LIGHTS	FOG LIGHTS	DASH LIGHTS	DOCK LIGHTS	BEACON	LIGHT
RP	YG	TX	VD	VE	VF	VG	SH	SM	SN	SP	SR	SY
DIM	BRIGHT						BILGE PUMP	BILGE				
WY	WZ	UH	UJ	PD	PE	PF	VC	VJ	UF	UG	MU	TN
		WIPER										
NS	PB	SE	VZ	YE	NN	RW	PU	WA	YN	UE	NM	RJ
				ENG FAN	BLWR					HORN		
NR	YD	TL	VR	SL	VA	UC	VN	PK	VY	UZ	RH	NU
								UP	DOWN			
NV	RB	RC	RK	RL	MZ	RG	WS	WT	UD	UR	WD	TY
		WATER PUMP		ANCHOR								
PA	UK	WR	UU	UT	YR	PM	VV	WB	TB	TC	TD	TE
											ENG HATCH	ENG BRAKE
MY	PV	TA	TZ	WC	PT	PN	PH	RA	TU	TT	YL	SK
						TCS						
VS	UL	UM	WK	TS	VT	WL	VP	YJ	PJ	RY	UP	NW
NP	RE	RF	PP	PR	TV	PC	YT	YU	PL	WJ	MV	RR
		SEAT					CRUISE					
TK	RT	SZ	VX	WF	WH	PG	SJ	YA	YB	RM	TM	RD
RS	UN	TP	TR	NT	MX	YC	TW	TJ	YF	TH	TF	TG
		AUX	ON OFF	OFF ON	I O	O I	O F F O N	ON	OFF	I	O	II
YS	YH	SX	RZ	YP	WN	WP	WW	WX	SA	SB	SC	SD
RAISE	LOWER	HIGH	LOW	FWD	REV	DEPTH	TRIM TAB	ACC	NAV ANCH	WIND LASS UP/DN	LIVE WELL	REAR
ST	SU	WU	WV	SV	SW	VB	VH	VK	VL	VM	WE	SF
PARK	AUTO											
SG	SS	RU	RV	RX								

Authorized Sales Representatives and Distributors

Click on a region of the map below to find your local representatives and distributors or visit www.carlingtech.com/findarep.



About Carling

Founded in 1920, Carling Technologies is a leading manufacturer of electrical and electronic switches and assemblies, circuit breakers, electronic controls, power distribution units, and multiplexed power distribution systems. With six ISO9001 and IATF16949 registered manufacturing facilities and technical sales offices worldwide, Carling Technologies Sales, Service and Engineering teams do much more than manufacture electrical components, they engineer powerful solutions! To learn more about Carling please visit www.carlingtech.com/company-profile.

To view all of Carling's environmental, quality, health & safety certifications please visit www.carlingtech.com/environmental-certifications.

© Carling Technologies, Inc.

10. Carling is a registered trademark of Carling Technologies, Inc. in the U.S. and other countries.