

# UKP-Series

J1939 Universal Keypads

**PRODUCT WEBPAGE**

*request sample, configure part, watch video*



The UKP-Series is a universal, customizable membrane keypad that is compliant with SAE J1939 CAN standards. With above and below sealing protection, the UKP-series can be installed inside or outside the cab. Each button features laser etched legends, up to three dimmable LED function lights, and tactile/audible feedback when pressed.

**12/24 VDC**   **1,000,000** Operations   **IP67 Sealing**  
 for above panel components

## Typical Applications

- Truck
- Bus
- Construction
- Mining
- Agricultural

# Design Features

## LOW PROFILE DESIGN

0.62 inch [15.92 mm] thickness (see dimensional specs for more detail)



Front View

## SEALING PROTECTION

IP67 above panel and below panel (when connected)

## LED FUNCTION LIGHTS

One, two, or three LED Function Lights per button. Colors include Amber, Green, Red or Blue

## CUSTOMIZABLE ICONS

Choose from our standard library of icons or use custom icons



Back View

## CONNECTOR

Mates to the Deutsch DT-Series Connector

## MOUNTING STUDS OR WINGS

M5 x 0.8mm Mounting Studs (2x3, 2x4, 2x5, 2x6)  
Mounting Wings (2x2)

# Related Products



**CLTM12-S-Series >**  
Load Controller



**CKJ-Series >**  
Jog Switch



**VM-Series >**  
Operator Control Module

# Tech Specs

## General

CAN Protocol	CAN 2.0b type interface as defined by SAE J1939
Illumination	LED backlit icons and function lights. Up to 3 function lights per button. Dimmable illumination, controlled by CAN messages
Connection/Wiring	Deutsch DT-Series 4 Pin connector
Operating Force	7 ± 3 N
Mounting	Clips or studs (See Dimensional Specs), Vertically or horizontally
Panel Cutout/Dimensions	See Dimensional Specs

## Electrical

Operating Voltage	Designed for 12/24 Volt systems Minimum 8VDC Maximum 32VDC
Sleep Mode	Defined as the state after a pre-defined time of non-activity to reduce current draw on the system, and wakes on keypress or CAN message
ESD	ISO 10605, ±15kV air discharge (x2), ±8kV contact discharge (x2)
Radiated Immunity-ALSE	ISO 11452-2, Absorbed-lined chamber enclosure field strength 100V/m, frequency from 80MHz to 2GHz, Class A
Bulk Current Injection	ISO 11452-4, Level 100mA, frequency from 1MHz to 400MHz, linear step, Class A
Conducted Transients	ISO 7637-2, All test pulses in Annex A Table A1 and A2, 2a/3a/3b/5a/5b-Class A
Radiation Emission	ISO 13766-1, Broadband and Narrowband for ESA, range 30-1000MHz
Over Voltage	ISO 16750-2, Power up with 36VDC for 60 min at 65 °C.
Short Circuit Protection	ISO 16750-2, All output terminal short to ground for 60s.
Reverse Polarity Protection	ISO 16750-2, 28V for 60s
Starting Profile	ISO 16750-2, Level IV $U_{Sg}=6V$ (12V) class B. Level I $U_{Sg}=10V$ (24V) class A
Withstand Voltage	ISO 16750-2, Apply 500VAC 60Hz for 60s
Insulation Resistance	ISO 16750-2, 500VDC for 60s, > 100MΩ
Superimposed Alternating Voltage	ISO 16750-2, UPP of 4 V for 120s, total 5 cycles
Slow Decrease and Increase of Supply Voltage	ISO 16750-2, Increase the supply voltage from 0V to $U_{Smin}$ , then decrease it from $U_{Smin}$ to 0V, applying a change rate of 0.5 V/min linear.
Momentary Drop in Supply Voltage	ISO 16750-2, Voltage drop from 8V to 4.5V, duration ≤ 100 ms.
EU Commission Directive	2004/104/EC Compliant (E-Marked)

## Environmental

Operating Temperature	-40°C to +85°C
Storage Temperature	-40°C to +85°C
Thermal	-40°C to +85°C IEC 60068-2-1: Cold Soak IEC 60068-2-2: Heat Soak IEC 60068-2-14: Cycling/Shock
Solar Radiation	IEC 60068-2-5, procedure B, Irradiation: 1120w/m <sup>2</sup> , Total Period: 15 day, Light: 20h, 70°C BST, 30%RH, 40°C CHT. Dark: 4h, 25°C BST, 93%RH, 25°C CHT
Low Pressure	IEC 60068-2-13
Humidity	Soak: IEC 60068-2-78, Soak at 40°C at 93% RH for 10 days Cyclic: IEC 60068-2-30, Method 1, Temp range from 25°C to 55°C, cycling change with 93±3% RH, 10 cycles for 240 hrs.
Ingress Protection	ISO 20653, IP67, for above panel components of actual switch only.
Salt Spray	IEC 60068-2-52, Salt mist for 2h at 35°C, dry for 4h at 35°C RH≤30%, and humid for 2h at 50°C RH≥95%. Repeat 12 cycles, total 96h.
Chemical Loads	ISO 16750-5, brushing engine oil, hydraulic oil, diesel fuel, Grease, Urea at 85°C for 22hrs. Dipping battery fluid for 22hrs and alcohol for 10min at 25°C.
Resistance for Rubbing	RCA Abrasion, 400 sweeps, 175g

## Mechanical

Endurance	1,000,000 cycles per key (20% at -40°C, 20% at +85°C, 60% at +25°C)
Vibration	Resonance Vibration: IEC 60068-2-6, 20Hz-500Hz per axis with amplitude of 19.6m/s <sup>2</sup> . Apply 90m/s <sup>2</sup> at resonance point for 1h at Z axis and 0.5h at X/Y axis.  Sinusoidal Vibration: IEC 60068-2-6, 5Hz~200Hz with amplitude 100m/s <sup>2</sup> for 4h at Z axis and 2h at X/Y axis.  Random vibration: IEC 60068-2-64, 10-2000Hz. Acceleration 5.825Grms, 8h per axial
Shock and Bump	IEC 60068-2-27, Shock 500 m/s <sup>2</sup> 11 milliseconds. IEC 60068-2-29, Bump 400 m/s <sup>2</sup> 6 milliseconds 600 cycles
Drop Test	IEC 60068-2-31, Free fall, Procedure 1, 1000 mm height, drop on all 3 axes in both directions

# Tech Specs

## Software Interface Integration

Click below to integrate the UKP-Series into J1939 CAN network:

[www.carlingtech.com/sites/default/files/documents/ukp-series\\_interface.pdf](http://www.carlingtech.com/sites/default/files/documents/ukp-series_interface.pdf)

## Tables

**Table A:** Standard Illumination

Type	Red	Green	Amber	Blue	White
Backlight	---	---	---	---	Yes
Function	Yes	Yes	Yes	Yes	---

**Connection:** 4 pin Deutsch DT Connector. Power with 8V to 32V vehicle type input

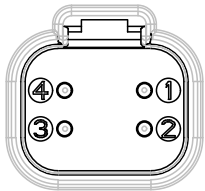

No.	Destination
1	Power
2	Ground
3	CAN H
4	CAN L

**Table B:** Operation Current Values

Size	Voltage	Sleep Current Value (mA)
2x2	12	~4.63
	24	~3.18
2x3	12	~6.67
	24	~4.27
2x4	12	~9.11
	24	~5.55
2x5	12	~8.84
	24	~5.40
2x6	12	~11.54
	24	~6.95

# Ordering Scheme

## Part 1: Keypad

Sample Part No. **UKP 1 - 5 1 - A B - A - J 128 /**

Selection 1 2 3 4 5 6 7 8 9

### 1. SERIES

**UKP** UKP-Series Keypad

### 2. KEYPAD STYLING

**1** Standard

### 3. BUTTON LAYOUT

<b>1</b> Two by Two	<b>6</b> Three by Two
<b>2</b> Two by Three	<b>7</b> Four by Two
<b>3</b> Two by Four	<b>8</b> Five by Two
<b>4</b> Two by Five	<b>9</b> Six by Two
<b>5</b> Two by Six	

### 4. KEYPAD COLOR

**1** Black

### 5. BACKLIGHT

**A** White

### 6. FUNCTION LIGHT COLOR

<b>B</b> Amber	<b>D</b> Red
<b>C</b> Green	<b>E</b> Blue

### 7. NON-ILLUMINATED IMAGE COLOR

**A** White

### 8. NETWORK TYPE

<b>J</b> J1939 (250K Baud Rate)
<b>K</b> J1939 (500K Baud Rate)

### 9. SOURCE ADDRESS <sup>1</sup>

The Source Address is a unique number (**000-248**) assigned to each node on a CAN network, and is determined based upon the specific CAN architecture of each customer application.

Notes:

- Default Source Address is 128.
- Source Address to be defined as the Decimal Value in the Ordering Scheme, unit will be programmed with Source Address as a Hexadecimal value when delivered.

[Configure Complete Part Number >](#)

## Part 2: Icon Artwork (Select 12 buttons for 2x6, 10 buttons for 2x5, 8 buttons for 2x4, 6 buttons for 2x3, and 4 buttons for 2x2.)

<p><b>Button 1</b></p> <p><b>2 RS</b></p> <p>Function Icon Code</p>	<p><b>Button 2</b></p> <p><b>2 RA</b></p> <p>Function Icon Code</p>	<p><b>Button 3</b></p> <p><b>3 UV</b></p> <p>Function Icon Code</p>	<p><b>Button 4</b></p> <p><b>3 UW</b></p> <p>Function Icon Code</p>	<p><b>Button 5</b></p> <p><b>6 MT</b></p> <p>Function Icon Code</p>	<p><b>Button 6</b></p> <p><b>8 UB</b></p> <p>Function Icon Code</p>
<p><b>Button 7</b></p> <p><b>8 NN</b></p> <p>Function Icon Code</p>	<p><b>Button 8</b></p> <p><b>8 PU</b></p> <p>Function Icon Code</p>	<p><b>Button 9</b></p> <p><b>5 PR</b></p> <p>Function Icon Code</p>	<p><b>Button 10</b></p> <p><b>5 PP</b></p> <p>Function Icon Code</p>	<p><b>Button 11</b></p> <p><b>4 RH</b></p> <p>Function Icon Code</p>	<p><b>Button 12</b></p> <p><b>4 NU</b></p> <p>Function Icon Code</p>

### FUNCTION LIGHT CODE

<p><b>1</b> No Function Light</p>	<p><b>5</b> Closed-Open-Open</p>
<p><b>2</b> Open-Closed-Closed</p>	<p><b>6</b> Open-Closed-Open</p>
<p><b>3</b> Closed-Open-Closed</p>	<p><b>7</b> Open-Open-Closed</p>
<p><b>4</b> Closed-Closed-Open</p>	<p><b>8</b> Open-Open-Open</p>

### ICON CODE

**00** For standard icons, see Standard Legends Code page. For additional icons, please consult factory.

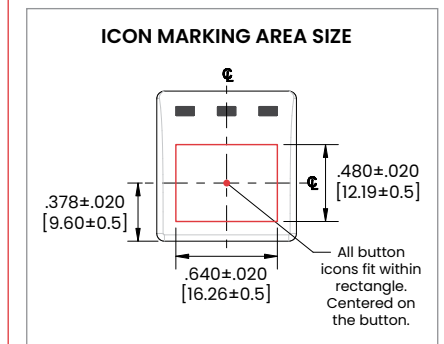

# Dimensional Specs

inches [millimeters]

## 2x2 and 2x3 Configurations

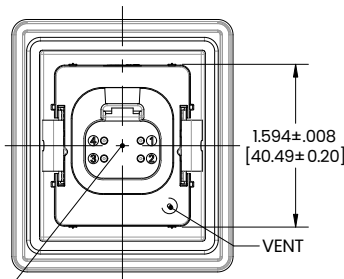
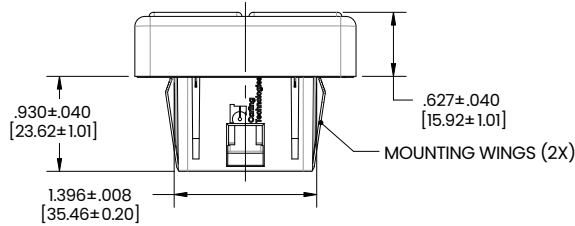
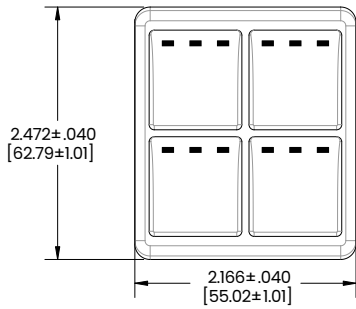

MATES TO THE DEUTSCH DT-SERIES CONNECTOR

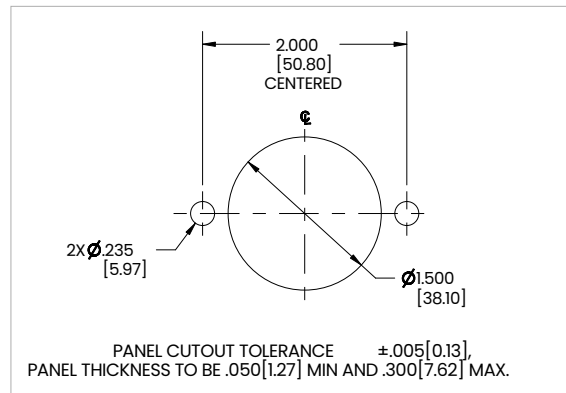
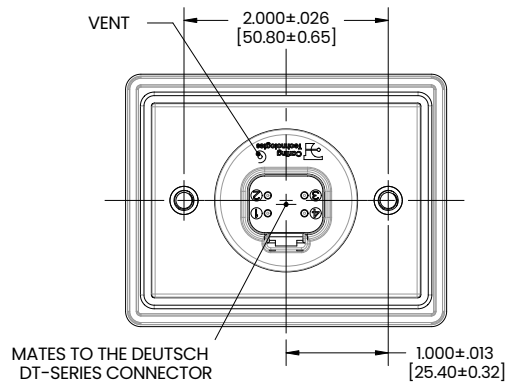
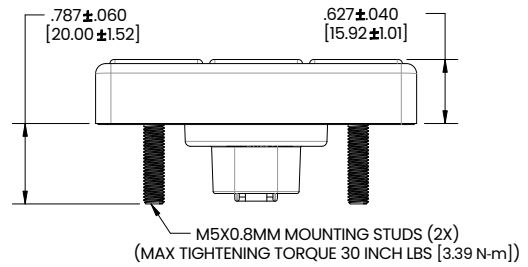
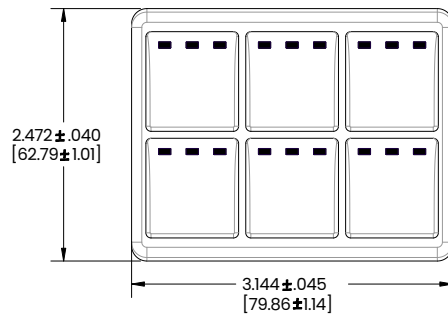
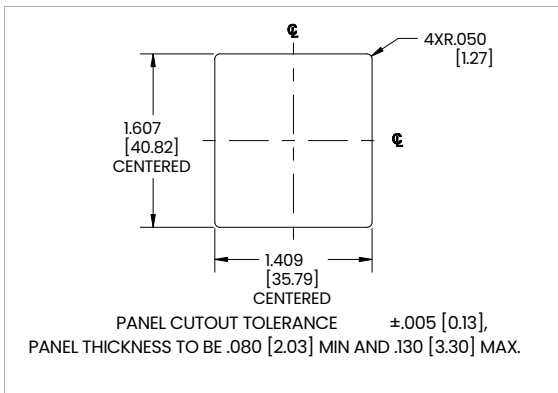

# Dimensional Specs

inches [millimeters]

## 2x4 and 2x5 Configurations

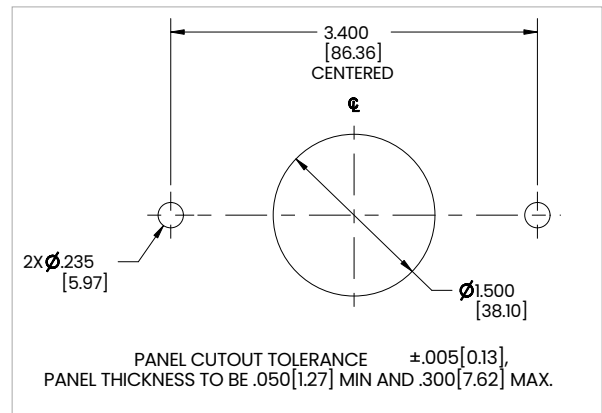
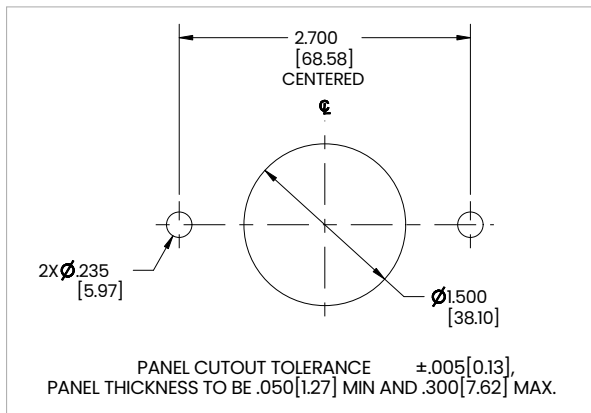
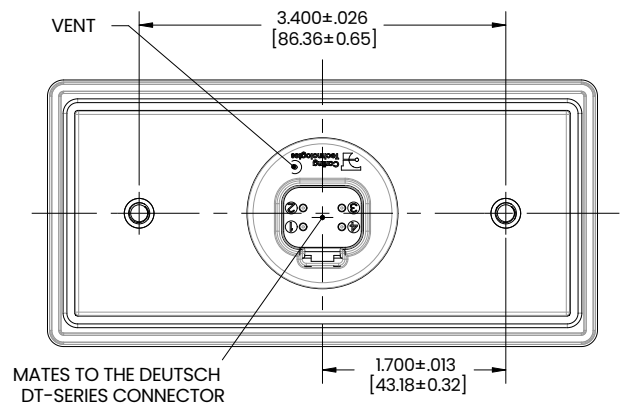
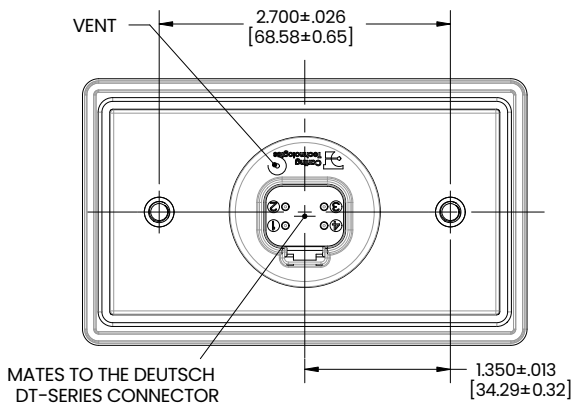
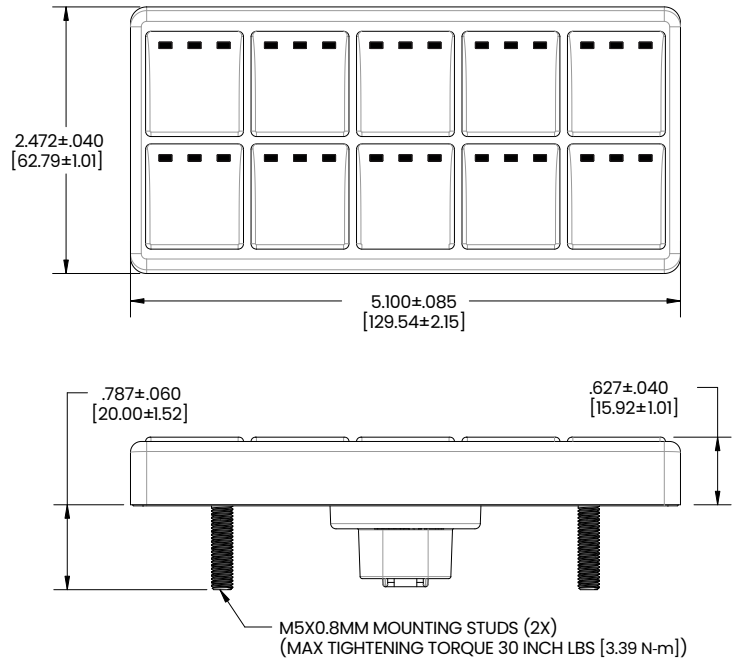
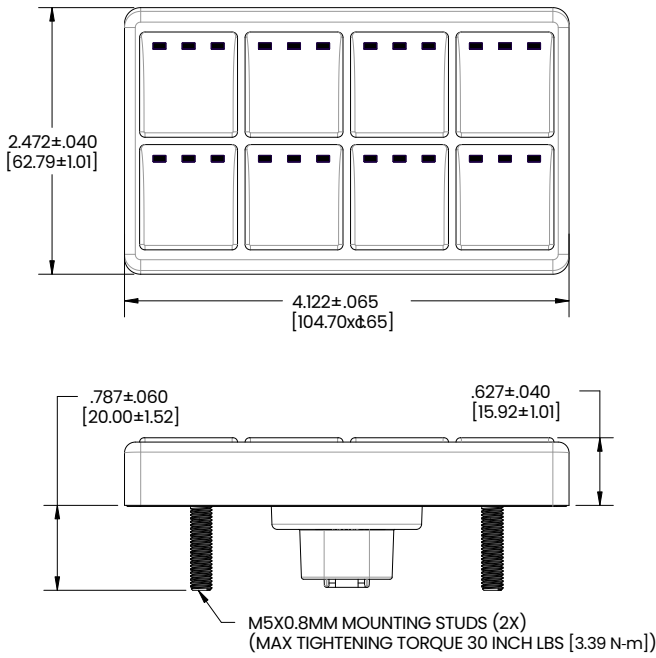

# Dimensional Specs

inches [millimeters]

## 2x6 and 6x2 Configurations

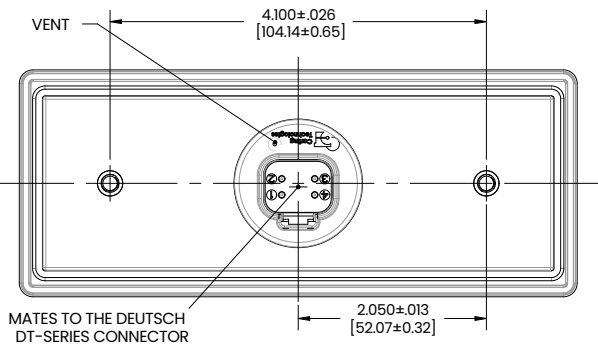
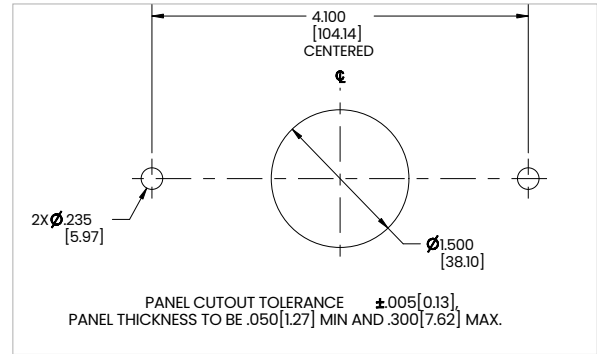
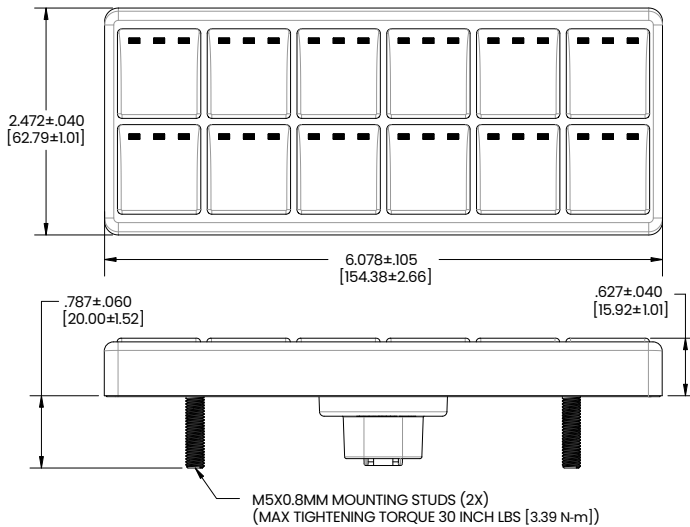

PIN OUT AS SHOWN BELOW

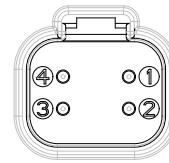

NO.	DESIGNATION
1	POWER
2	GROUND
3	CAN H
4	CAN L

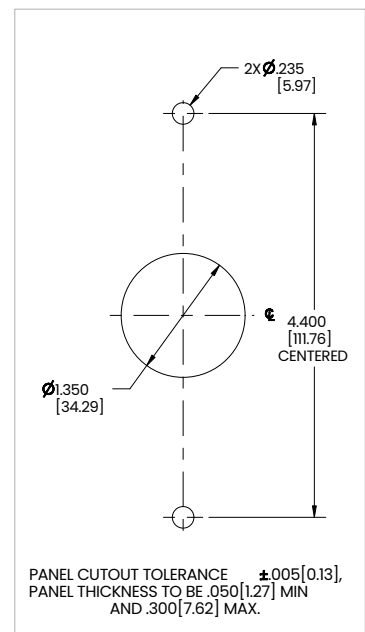
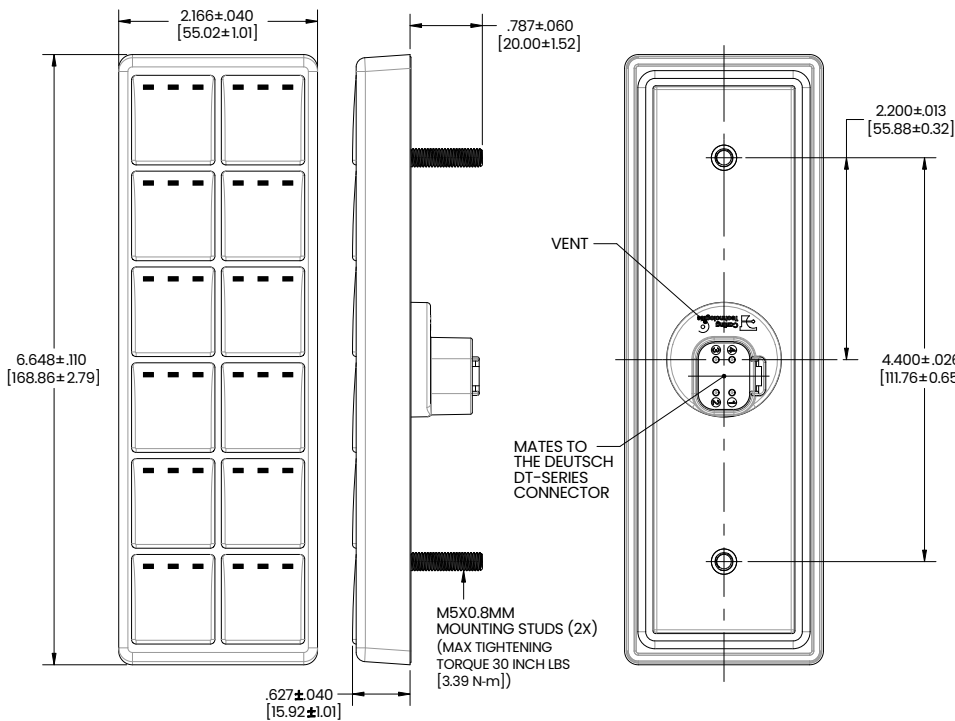



# Dimensional Specs

inches [millimeters]

## 3x2, 4x2 and 5x2 Configurations

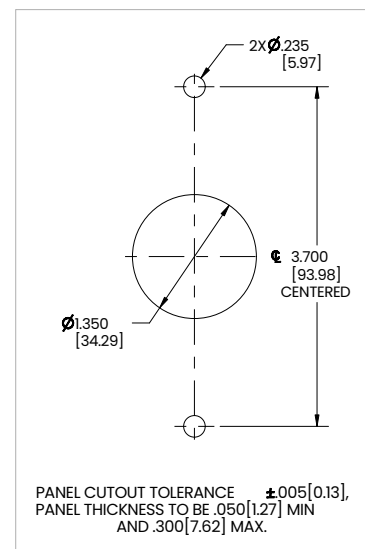
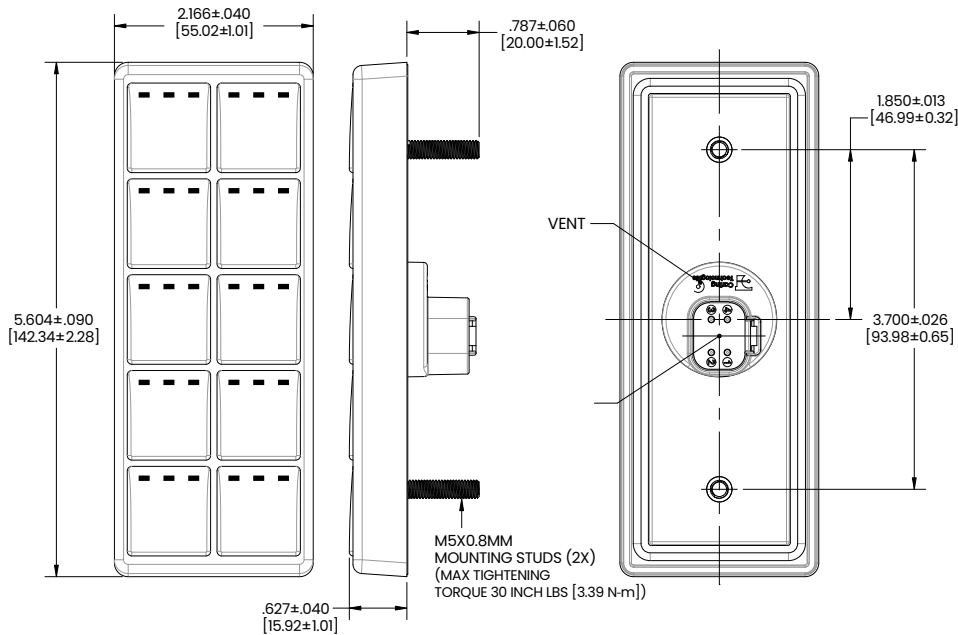
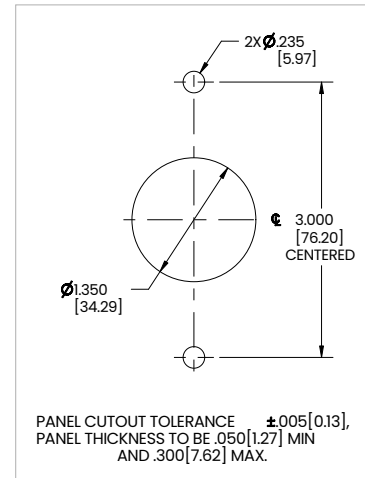
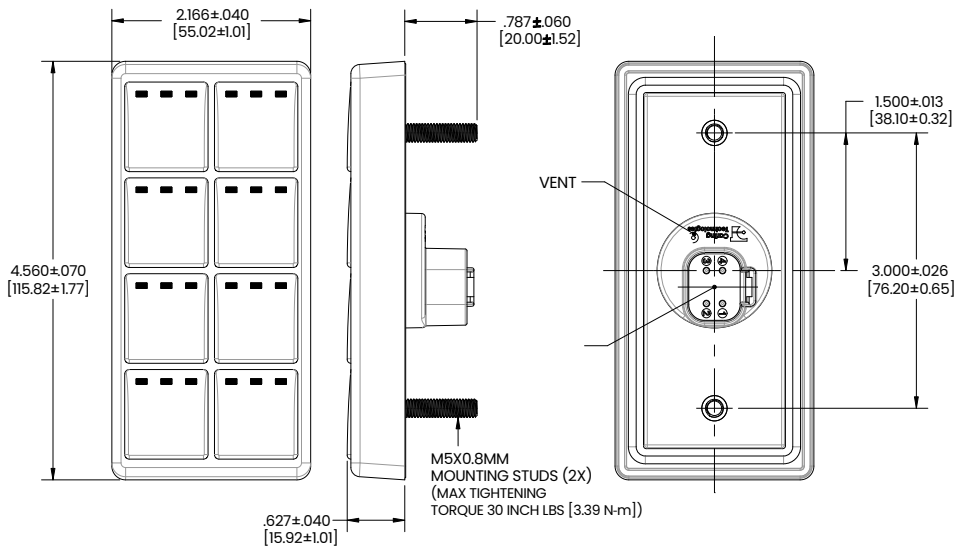
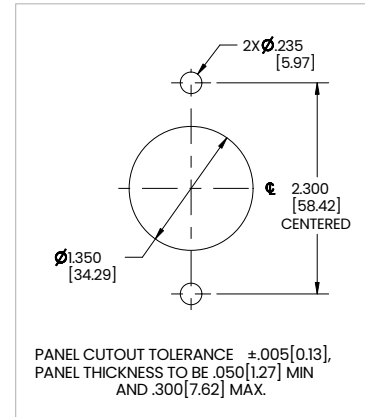
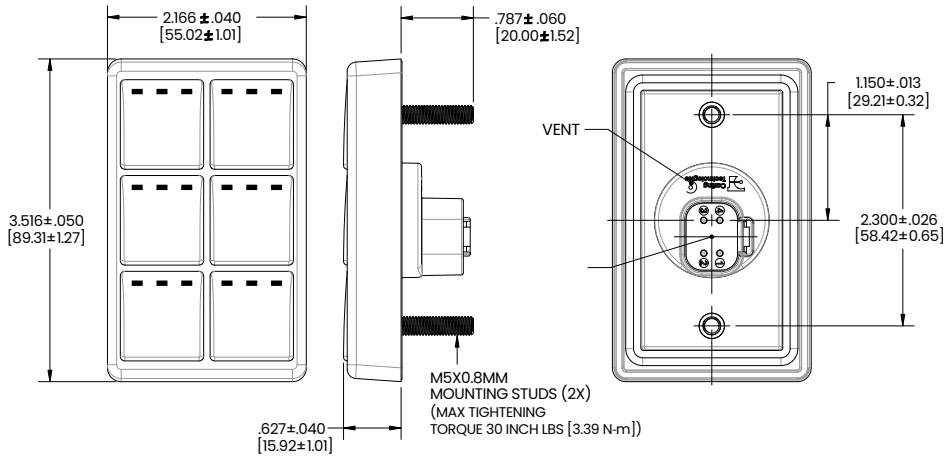

# Standard Legend Codes

YK	UA	UB	US	UV	UW	UX	UY	MP	MR	PX	MS	MT
VU	MW	NZ	NX	NY	YM	VW	PS	PW	PZ	WG	WM	RN
			NAV LIGHTS	COURT LIGHTS	PANEL LIGHTS	ANCH LIGHTS	HEAD LIGHTS	FOG LIGHTS	DASH LIGHTS	DOCK LIGHTS	BEACON	LIGHT
RP	YG	TX	VD	VE	VF	VG	SH	SM	SN	SP	SR	SY
DIM	BRIGHT						BILGE PUMP	BILGE				
WY	WZ	UH	UJ	PD	PE	PF	VC	VJ	UF	UG	MU	TN
		WIPER										
NS	PB	SE	VZ	YE	NN	RW	PU	WA	YN	UE	NM	RJ
				ENG FAN	BLWR					HORN		
NR	YD	TL	VR	SL	VA	UC	VN	PK	VY	UZ	RH	NU
							UP	DOWN				
NV	RB	RC	RK	RL	MZ	RG	WS	WT	UD	UR	WD	TY
		WATER PUMP			ANCHOR							
PA	UK	WR	UU	UT	YR	PM	VV	WB	TB	TC	TD	TE
											ENG HATCH	ENG BRAKE
MY	PV	TA	TZ	WC	PT	PN	PH	RA	TU	TT	YL	SK
							TCS					
VS	UL	UM	WK	TS	VT	WL	VP	YJ	PJ	RY	UP	NW
NP	RE	RF	PP	PR	TV	PC	YT	YU	PL	WJ	MV	RR
		SEAT					CRUISE					
TK	RT	SZ	VX	WF	WH	PG	SJ	YA	YB	RM	TM	RD
RS	UN	TP	TR	NT	MX	YC	TW	TJ	YF	TH	TF	TG
		AUX	ON OFF	OFF ON	I O	O I	OFF ON	ON	OFF	I	O	II
YS	YH	SX	RZ	YP	WN	WP	WW	WX	SA	SB	SC	SD
RAISE	LOWER	HIGH	LOW	FWD	REV	DEPTH	TRIM TAB	ACC	NAV ANCH	WIND LASS UP/DN	LIVE WELL	REAR
ST	SU	WU	WV	SV	SW	VB	VH	VK	VL	VM	WE	SF
PARK	AUTO											
SG	SS	RU	RV	RX								

## Authorized Sales Representatives and Distributors

Click on a region of the map below to find your local representatives and distributors or visit [www.carlingtech.com/findarep](http://www.carlingtech.com/findarep).



## About Carling

Founded in 1920, Carling Technologies is a leading manufacturer of electrical and electronic switches and assemblies, circuit breakers, electronic controls, power distribution units, and multiplexed power distribution systems. With six ISO9001 and IATF16949 registered manufacturing facilities and technical sales offices worldwide, Carling Technologies Sales, Service, and Engineering teams do much more than manufacture electrical components; they engineer powerful solutions! To learn more about Carling please visit [www.carlingtech.com/company-profile](http://www.carlingtech.com/company-profile).

To view all of Carling's environmental, quality, health & safety certifications please visit [www.carlingtech.com/environmental-certifications](http://www.carlingtech.com/environmental-certifications).

© Carling Technologies, Inc.

11. Carling is a registered trademark of Carling Technologies, Inc. in the U.S. and other countries.